

## CRIO Chill Smart Blast Chiller Crosswise 6 1/1 - 10kg

ITEM # \_\_\_\_\_

MODEL # \_\_\_\_\_

NAME # \_\_\_\_\_

SIS # \_\_\_\_\_

AIA # \_\_\_\_\_



728525 (EABP0071)

Blast chiller 10kg, compatible with 6x1/1GN crosswise oven (R134a)

### Short Form Specification

**Item No.** \_\_\_\_\_

For 6 GN1/1 or 5 600x400 mm trays. Load capacity: chilling 10 kg; (UK guidelines). Main components in 304 AISI stainless steel. Internal rounded corners and drain. Right hinged, reversible full door. Built-in refrigeration unit. Automatic and Manual defrost. Blast chilling real residual time estimation (A.R.T.E.). Turbo cooling function. Specific cycles for ice cream. Evaporator with antirust protection. Digital temperature and time display. HACCP and Service alarms with data logging. Operating air temperature: +90 -12°C. For ambient temperatures up to 32°C. Cyclopentane insulation (HCFC, CFC and HFC free). R134a refrigerant gas (HCFC and CFC free).

### Main Features

- Blast Chilling cycle: 10 kg from 90°C up to 3°C in less than 90 minutes.
- Hard Chilling (air temperature -12°C).
- Holding at 3 °C for chilling, automatically activated at the end of each cycle, to save energy and maintain the target temperature (manual activation is also possible).
- Turbo cooling: chiller works continuously at the desired temperature; ideal for continuous production.
- Control unit provides two large displays to read out: time, core temperature, cycle countdown, alarms, service information.
- Two customizable cycles (P1 & P2) for each operating mode, allowing to set the time and air temperature. These programs can be converted into ice-cream specialized cycles (shape maintenance and holding).
- All information related to the different operating models are recorded: date, time, cycle, core temperature, holding temperature, HACCP accordance.
- Automatic and manual defrosting.
- Soft Chilling (air temperature -2°C).
- Performance guaranteed at ambient temperatures of +40°C.

### Construction

- High density polyurethane insulation, 60 mm thickness, HCFC free.
- 304 AISI stainless steel construction throughout.
- Seamless hygienic inner cell with all rounded corners for easy cleaning.
- Swing hinged front panel for easy service access to main components.
- Ventilator swinging hinged panel for access to the evaporator for cleaning.
- No water connections required.
- Waste water can be plumbed into drain, but can also be collected in an optional waste container.
- Refrigerant type: R134a.
- Built-in refrigeration unit.
- Removable magnetic door gasket with hygienic design.
- 6 levels available. Usable with 5 GN 1/1 or 600x400 mm trays.

### Optional Accessories

- Kit of HACCP advanced connection for blast chiller and blast chillers/freezers PNC 880183
- 1 single sensor probe for blast chiller and blast chillers&freezer PNC 880213
- 4 feet for undercounter blast chillers/blast chiller freezers PNC 880338
- Rilsan grid 600x400mm PNC 880864
- Plastic coated grid for refrigerated counters PNC 881061
- Pair of 1/1GN grids in 304 AISI PNC 921101
- ETHERNET CONNECTOR FOR ECAP PROTOCOL ITEMS PNC 922768

APPROVAL: \_\_\_\_\_

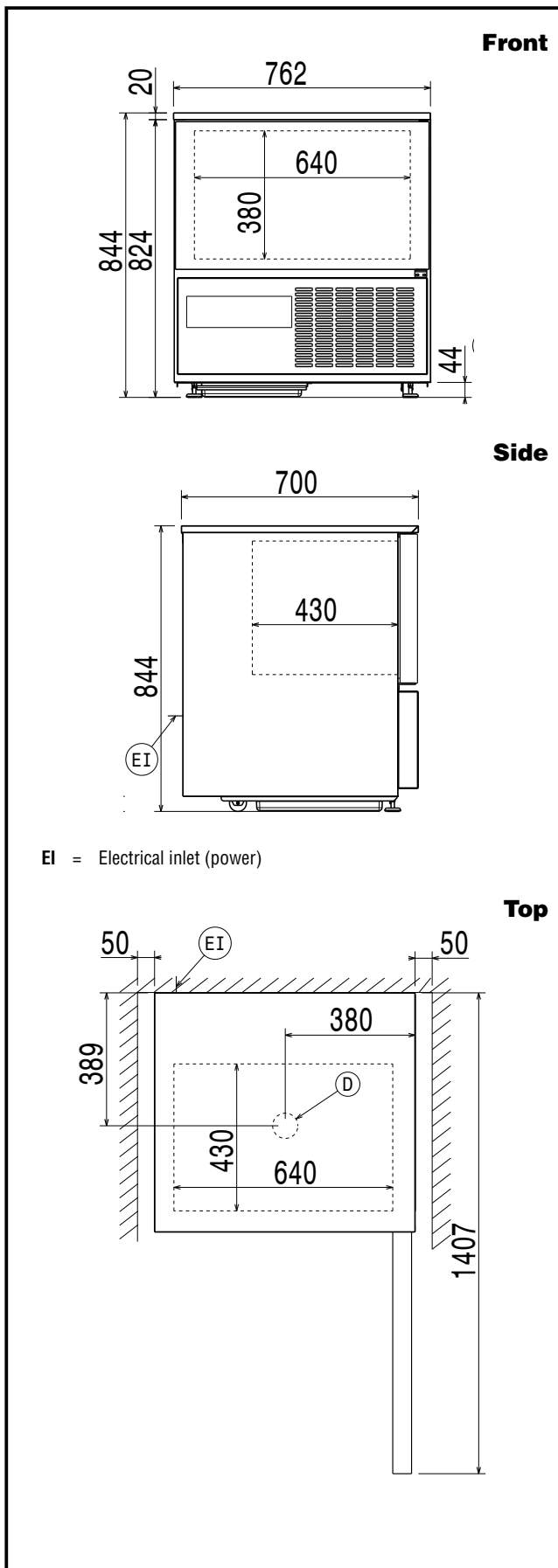

### Electric

Supply voltage:	728525 (EABP0071)	230 V/1 ph/50 Hz
Electrical power max.:		0.64 kW
Circuit breaker required		

### Installation:

Clearance:	5 cm on sides and back.
Please see and follow detailed installation instructions provided with the unit	

### Capacity:

GN:	6 - 1/1 containers
Max load capacity:	10 kg

### Key Information:

External dimensions, Width:	762 mm
External dimensions, Depth:	700 mm
External dimensions, Height:	844 mm
Net weight:	88 kg
Shipping weight:	98 kg
Shipping volume:	0.69 m <sup>3</sup>
Chilling-Freezing Productivity per cycle (NF Regulations):	7.2 kg - 0 kg
Chilling-Freezing Productivity per cycle (UK Guidelines):	10 kg - 0 kg

### Refrigeration Data

Control type:	Electronic
Refrigeration power at evaporation temperature:	-5 °C

### Product Information (EN17032 - Commission Regulation EU 2015/1095)

Chilling Cycle Time (+65°C to +10°C):	119 min
Full load capacity (chilling):	15 kg

### Sustainability

Refrigerant type:	R134a
Refrigeration power:	791 W
Refrigerant weight:	480 g
Energy consumption, cycle (chilling):	0.0655 kWh/kg